

SERIES F7319-JIS 10K

Cast Steel Angle Valve

SERIES F7471-JIS 10K

Cast Steel Angle Valve (SDNR)

Manufactured in accordance to JIS F7400

Flanges as per JIS B2220-10K

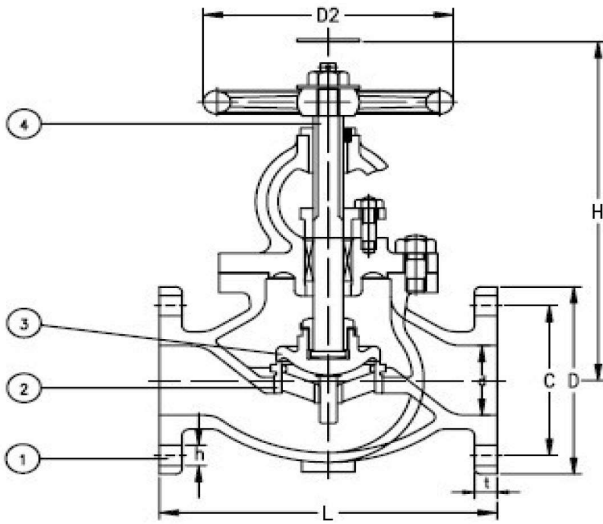

Series F7319

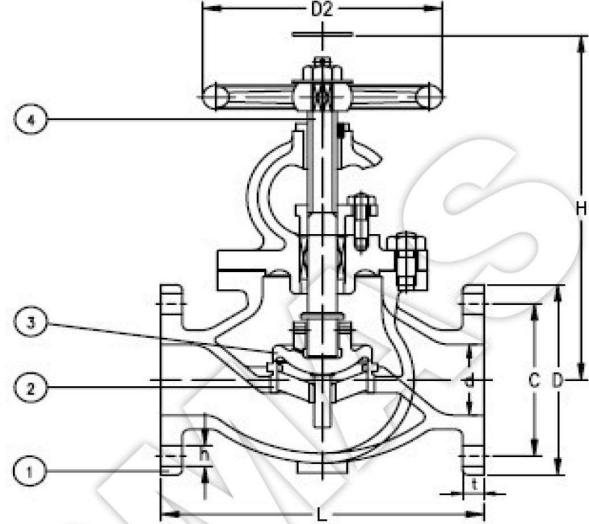

Series F7471-SDNR

Part Nr.	Material	Code
1- Body	Cast Steel	SC49(SC480)
2- Seat	SUS/Bronze	SCS2/BC6
3- Disc	SUS/Bronze	SCS2/BC6
4- Stem	SUS/Brass	SUS403/C3771BD

	Test Pressure MPa[kgf/cm ²]
Body	2.06[21.0]
Seat	1.51[15.4]

Size	L	D	C	NO	h	t	H	D2	Weight[kg]	
									F7319	F7471
50	220	155	120	4	19	16	270	160	17.9	17.9
65	270	175	140	4	19	18	300	200	26	26.1
80	300	185	150	8	19	18	310	200	29.8	29.8
100	350	210	175	8	19	18	355	250	44.7	44.8
125	420	250	210	8	23	20	415	280	70.3	69.8
150	490	280	240	8	23	22	470	315	96.4	96.3
200	570	330	290	12	23	22	565	355	159	158
250	740	400	355	12	25	24	645	400	257	257
300	840	445	400	16	25	24	735	500	370	370
350	940	490	445	16	25	26	840	560		
400	840	445	400	16	25	24	735	500		