

Series F7399-JIS 5K and 10K (Series CBM1104-82) Fuel Oil Tank Emergency Shut-Off Valve

Manufactured in accordance to JIS F7400

Flanges as per JIS B2210 & B2240-5K/10K

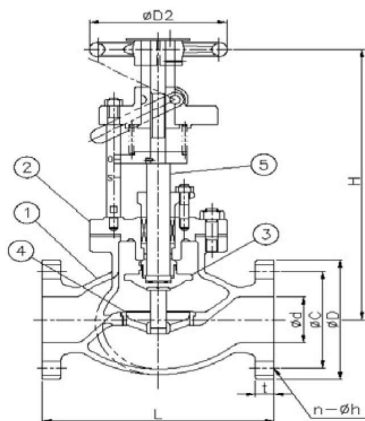

Type A

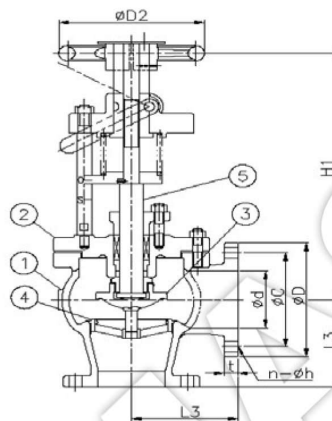

Type L

***Shut-off Operation:**

**Wire Rope Pull type
Pneumatic Control type**

Part Nr.	Material	Code
1- Body	Bronze/Cast Steel	CAC406/SC480
2- Bonnet	Bronze/Cast Steel	CAC406/SC480
3- Disc	Bronze/SUS	CAC406/SCS2
4- Seat	Bronze/SUS	CAC406/SCS2
5- Stem	Brass/SUS	C3771BD/SUS403

	Test pressure MPa[kgf/cm ²]
Body	0.7[7kg]
Seat	0.2[2kg]

Size	5K Flanged							10K Flanged							H	H1	D1	KG 5K	KG 10K
	L	L1	D	C	No	h	t	L	L1	D	C	No	h	t					
15	120	55	80	60	4	12	9	130	70	95	70	4	15	12	260	240	120	7.7	7.7
20	120	60	85	65	4	12	10	130	75	100	75	4	15	14	253	250	120	7.7	9.2
25	120	65	95	75	4	12	10	130	85	125	90	4	19	14	265	250	140	8.8	16.6
32	140	80	115	90	4	15	12	160	95	135	100	4	19	16	265	275	140	13.0	17.0
40	160	85	120	95	4	15	12	170	100	140	105	4	19	16	310	275	140	15.0	21.8
50	210	100	130	105	4	15	14	220	120	155	120	4	19	16	335	305	160	19.5	32.1
65	250	115	155	130	4	15	14	270	130	175	140	4	19	18	395	355	200	30.5	37.5
80	280	130	180	145	4	19	14	300	140	185	150	8	19	18	420	370	200	35.4	59.2
100	340	150	200	165	8	19	16	350	160	210	175	8	19	18	510	450	250	55.6	55.6
125	410	170	235	200	8	19	16	420	180	250	210	8	23	20	570	515	280	62.0	62.0
150	480	190	265	230	8	19	18	490	205	280	240	8	23	22	595	575	315	80.0	80.0
200	570	220	320	280	8	23	20	570	230	330	290	12	23	22	625	605	355	159.0	159.0
250	740	275	385	345	12	23	22	740	290	400	355	12	23	24	645	645	400	257.0	257.0